



LUMINOSO
70cm Cooker Hood
User Guide

1. SAFETY INFORMATION

i For your safety and correct operation of the appliance, read this manual carefully before installation and use. Always keep these instructions with the appliance even if you move or sell it. Users must fully know the operation and safety features of the appliance.



The wire connection has to be done by specialized technician.

- The manufacturer will not be held liable for any damages resulting from incorrect or improper installation.
- The minimum safety distance between the cooker top and the extractor hood is 650 mm (some models can be installed at a lower height, please refer to the paragraphs on working dimensions and installation).
- If the instructions for installation of the gas hob specify a greater distance, this must be respected.
- Check that the mains voltage corresponds to that indicated on the rating plate fixed to the inside of the hood.
- Means for disconnection must be incorporated in the fixed wiring in accordance with the wiring rules.
- For Class I appliances, check that the domestic power supply

- guarantees adequate earthing.
- Connect the extractor to the exhaust flue through a pipe of minimum diameter 120 mm. The route of the flue must be as short as possible.
- Regulations concerning the discharge of air have to be fulfilled.
- Do not connect the extractor hood to exhaust ducts carrying combustion fumes (boilers, fireplaces, etc.).
- If the extractor is used in conjunction with non-electrical appliances (e.g. gas burning appliances), a sufficient degree of aeration must be guaranteed in the room in order to prevent the backflow of exhaust gas. When the cooker hood is used in conjunction with appliances supplied with energy other than electric, the negative pressure in the room must not exceed 0,04 mbar to prevent fumes being drawn back into the room by the cooker hood.
- The air must not be discharged into a flue that is used for exhausting fumes from appliances burning gas or other fuels.
- If the supply cord is damaged, it must be replaced from the manufacturer or its service agent.
- The appliance must be installed in such a way as to allow disconnection from

the electrical power supply with a contact aperture (3 mm) that ensures complete disconnection in category III overload conditions.

- Connect the product to the mains using an omnipolar switch.
- With regards to the technical and safety measures to be adopted for fume discharging it is important to closely follow the regulations provided by the local authorities.

 **WARNING:** Before installing the Hood, remove the protective films.

- Use only screws and small parts supplied with the hood.

 **WARNING:** Failure to install the screws or fixing device in accordance with these instructions may result in electrical hazards.

- Do not look directly at the light through optical devices (binoculars, magnifying glasses...).
- Do not flambè under the range hood; risk of fire.
- This appliance can be used by children aged from 8 years and above and persons with reduced physical, sensory or mental capabilities or lack of experience and knowledge if they have been given supervision or instruction concerning use of the appliance

in a safe way and understand the hazards involved. Children shall not play with the appliance. Cleaning and user maintenance shall not be made by children without supervision.

- Children should be supervised to ensure that they do not play with the appliance.
- The appliance is not to be used by persons (including children) with reduced physical, sensory or mental capabilities, or lack of experience and knowledge, unless they have been given supervision or instruction.

 Accessible parts may become hot when used with cooking appliances.

- Clean and/or replace the Filters after the specified time period (Fire hazard). See paragraph Care and Cleaning.
- There shall be adequate ventilation of the room when the range hood is used at the same time as appliances burning gas or other fuels (not applicable to appliances that only discharge the air back into the room).
- The symbol  on the product or on its packaging indicates that this product may not be treated as household waste. Instead it shall be handed over to the applicable collection point for the recycling of

electrical and electronic equipment. By ensuring this product is disposed of correctly, you will help prevent potential negative consequences for the environment and human health, which could otherwise be caused by inappropriate waste handling of this product. For more detailed information about recycling of this product, please contact your local city office, your household waste disposal service or the shop where you purchased the product.

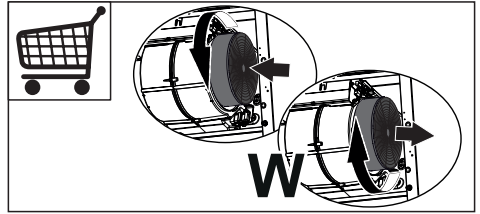

- The Grease filters must be cleaned every 2 months of operation, or more frequently for particularly heavy usage, and can be washed in a dishwasher (**Z**). The grease filters may slightly change colour following washing, however this does not affect their performance.

2. USE

- The extractor hood has been designed exclusively for domestic use to eliminate kitchen smells.
- Never use the hood for purposes other than those for which it has been designed.
- Never leave high naked flames under the hood when it is in operation.
- Adjust the flame intensity to direct it onto the bottom of the pan only, making sure that it does not engulf the sides.
- Deep fat fryers must be continuously monitored during use: overheated oil can burst into flames.

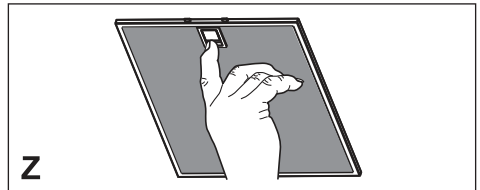

- Clean the hood using a damp cloth and a neutral liquid detergent.

3. CARE AND CLEANING

- The Activated charcoal filter is not washable and cannot be regenerated, and must be replaced approximately every 4 months of operation, or more frequently for particularly heavy usage (**W**). Carbon filters can be obtained from our Customer Care (details at the rear of the handbook).

4. CONTROLS

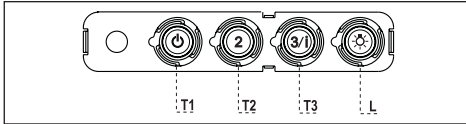

BUTTON	LED	FUNCTIONS
T1 Speed	On	Turns the Motor on at Speed one.
		Turns the Motor off.
T2 Speed	On	Turns the Motor on at Speed two.
T3 Speed	Fixed	When pressed briefly, turns the Motor on at Speed three.
	Flashing	Pressed for 2 Seconds. Activates Speed four with a timer set to 6 minutes, after which it returns to the speed that was set previously. Suitable to deal with maximum levels of cooking fumes.
L Light		Turns the Lighting System on and off.

Warning: Button **T1** turns the motor off, after first passing to speed one.

5. LIGHTING

- Replacement parts can be obtained from our Customer Care (details at the rear of the handbook).

EN INSTALLATION MANUAL

Warning! Before proceeding with installation, read the safety information in the User Manual.



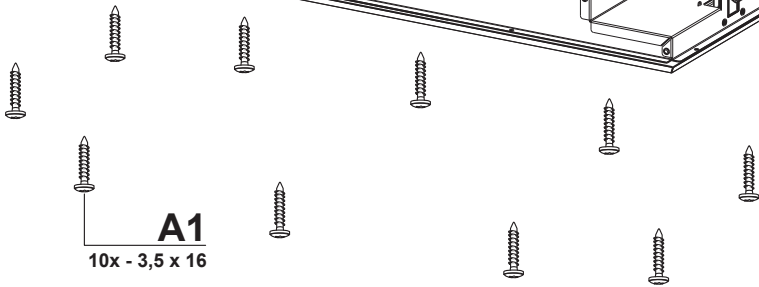
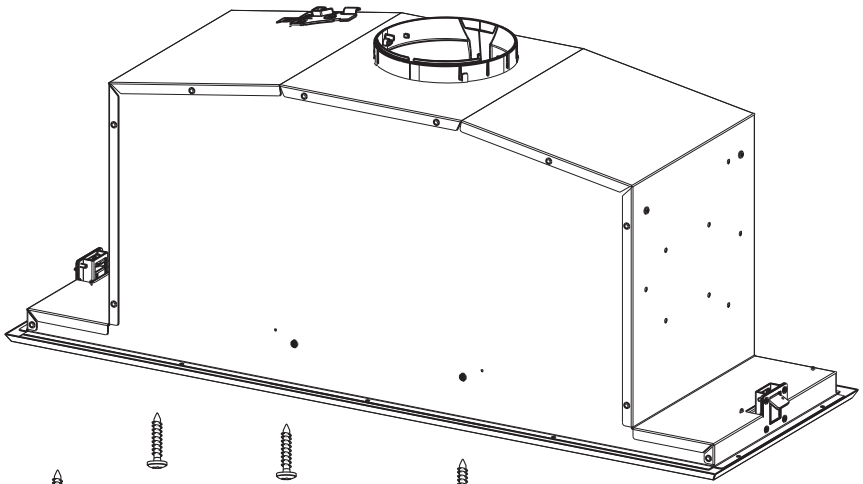
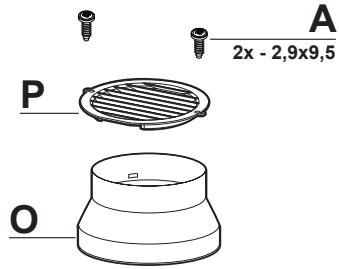

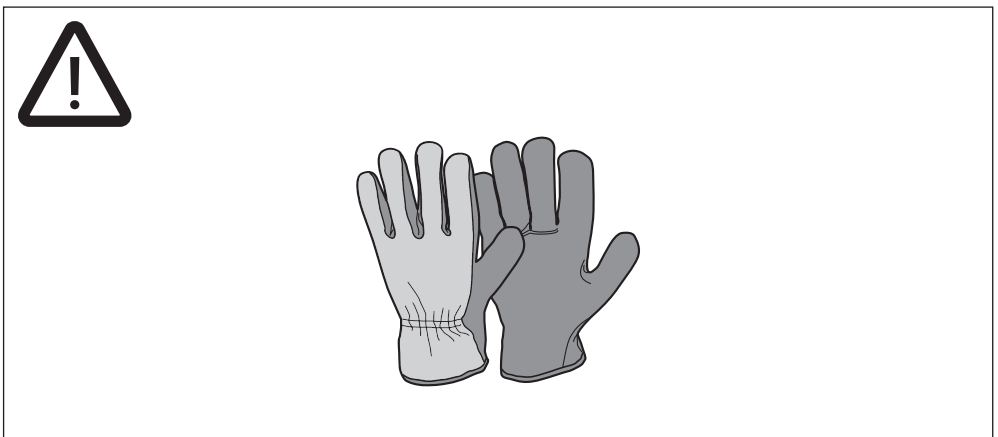
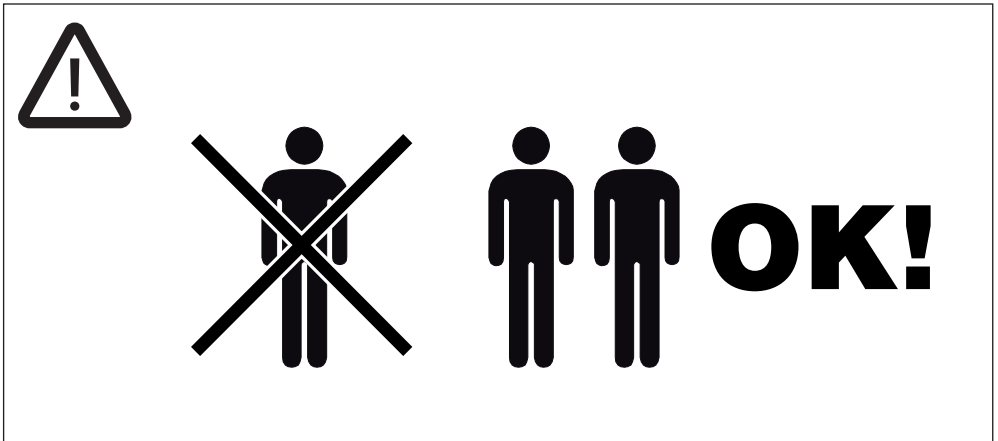
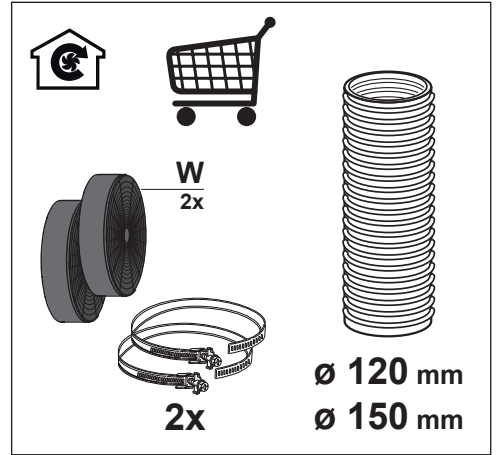
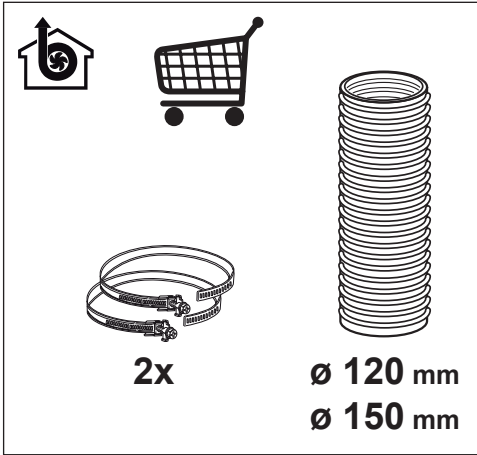

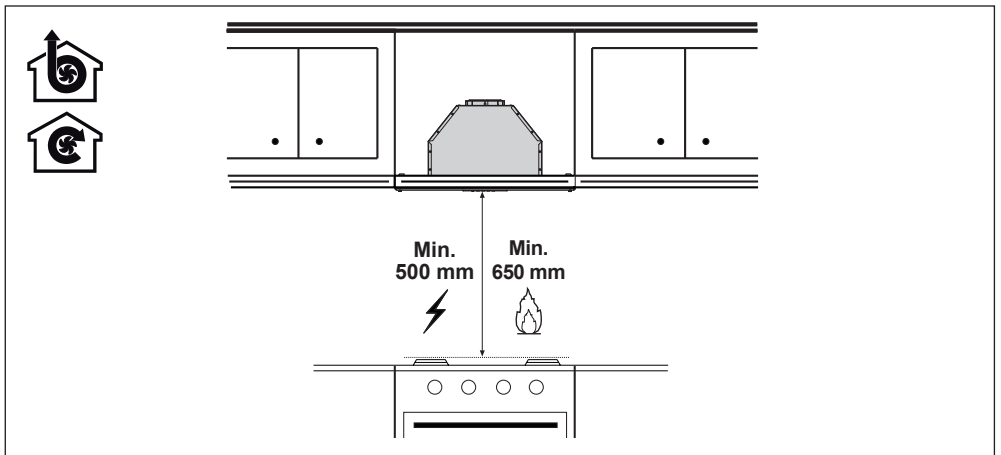
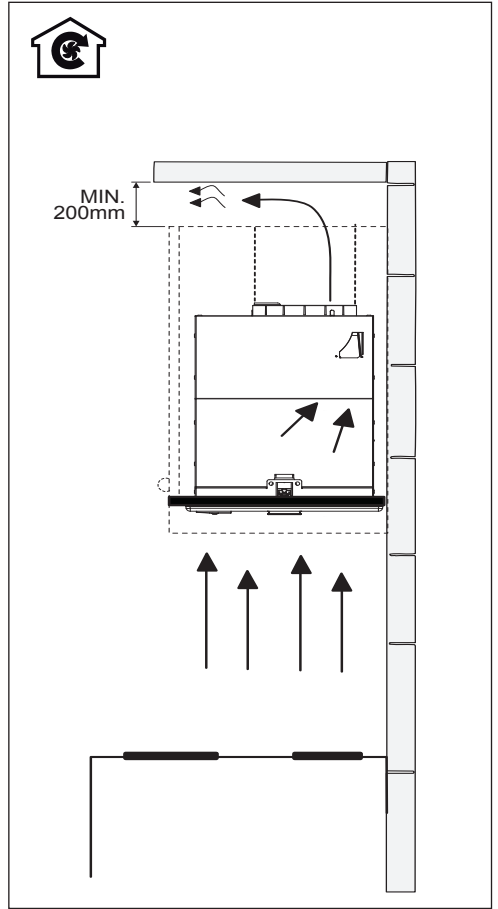
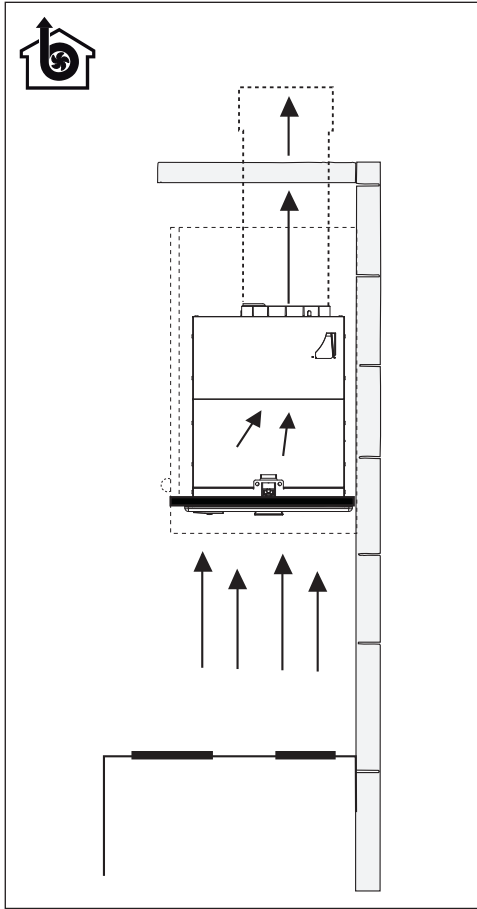

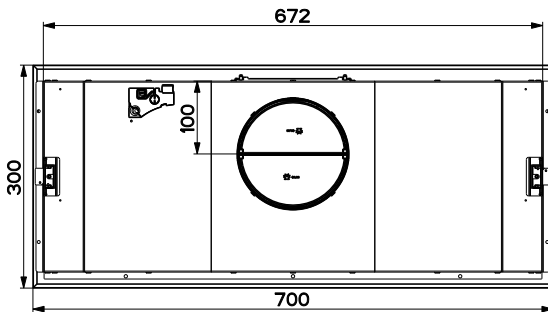
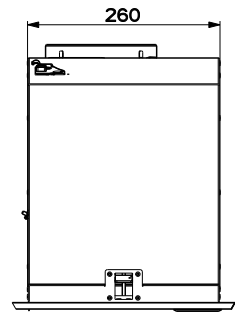
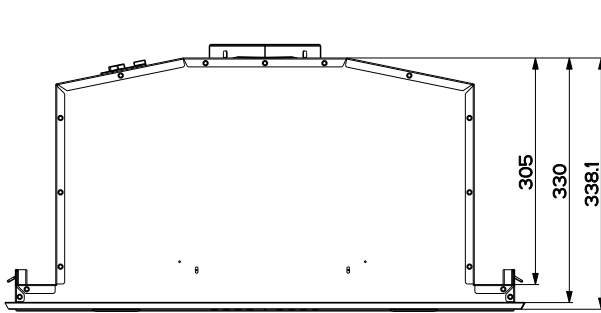
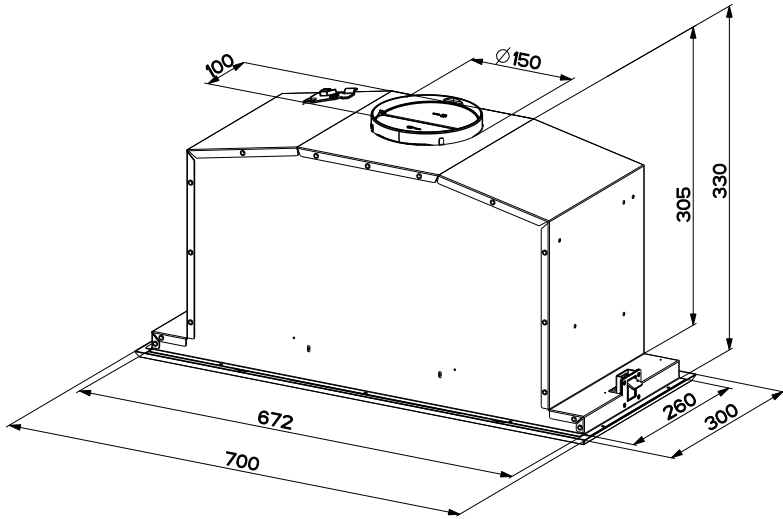

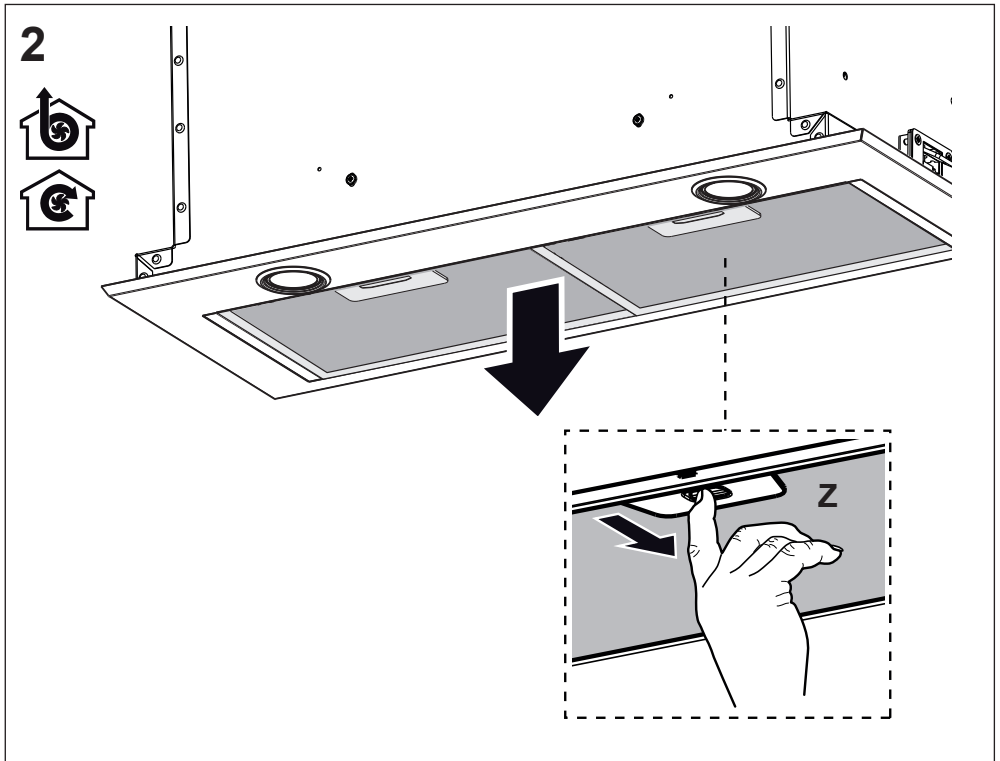
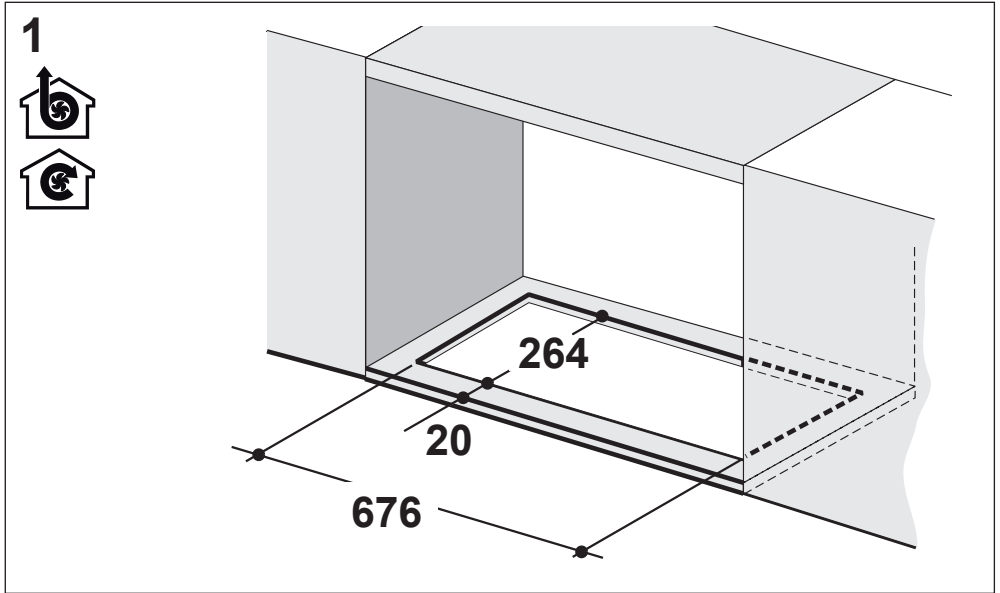

3

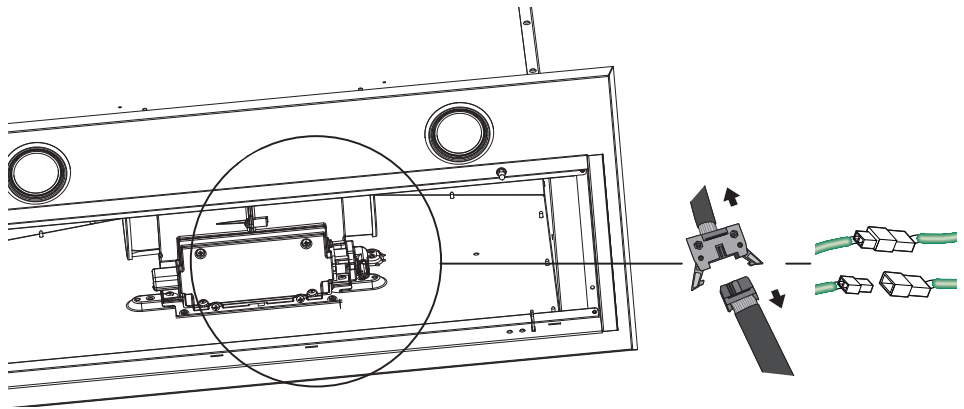
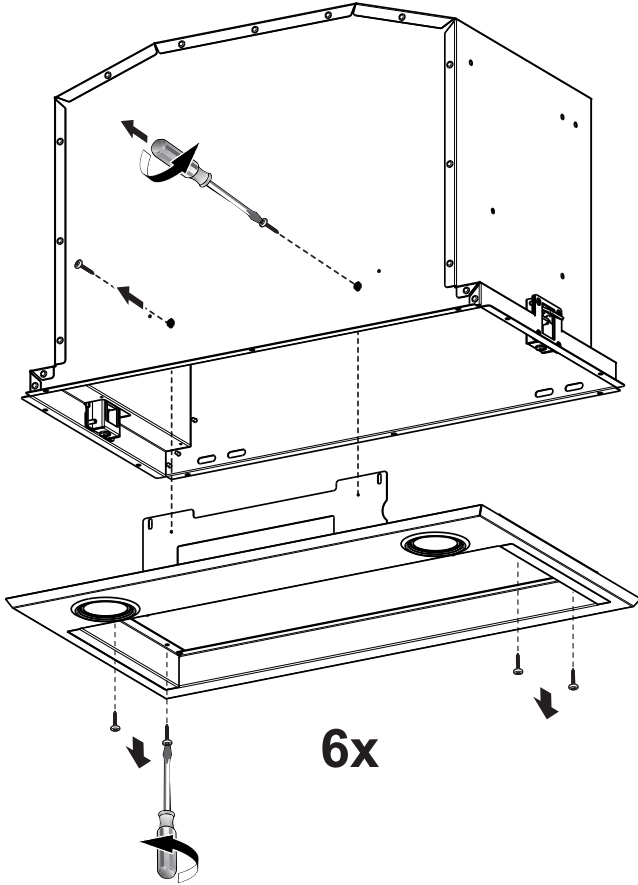

4

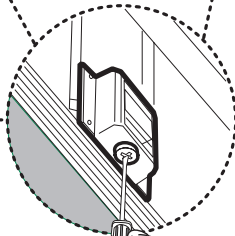
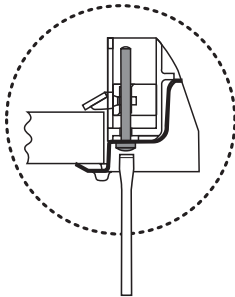
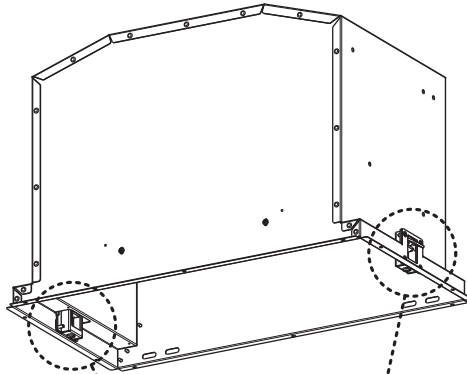
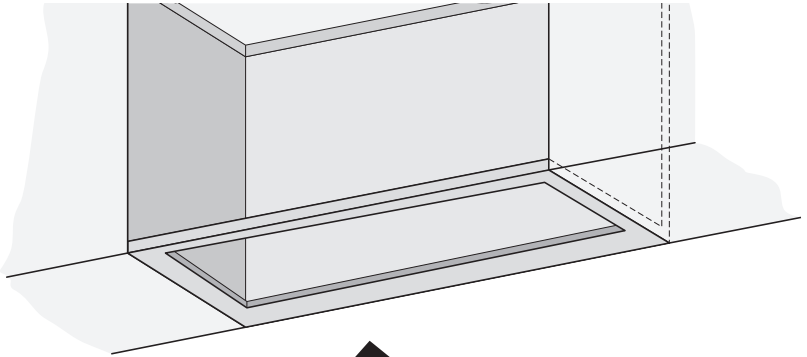

2x

5

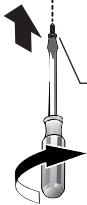
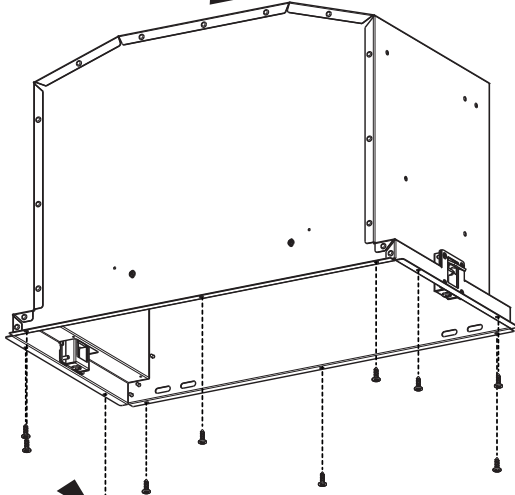
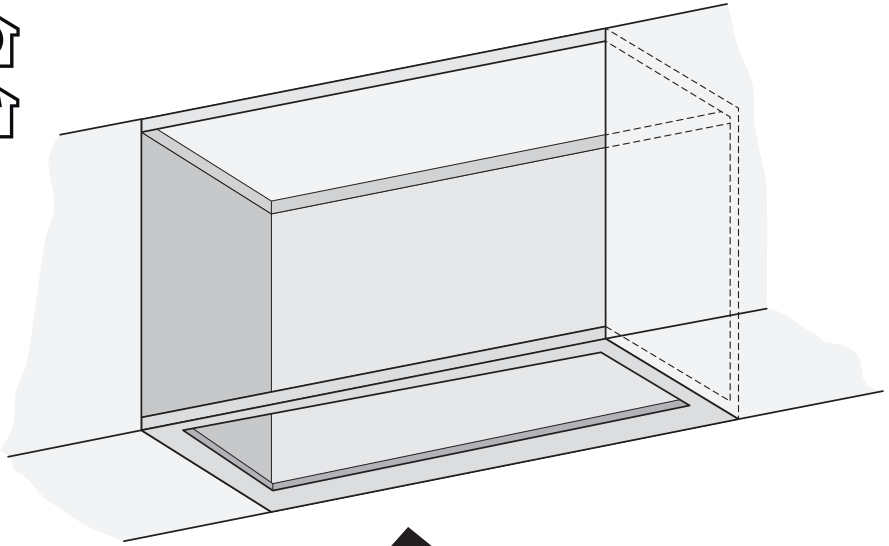

A1
10x

6

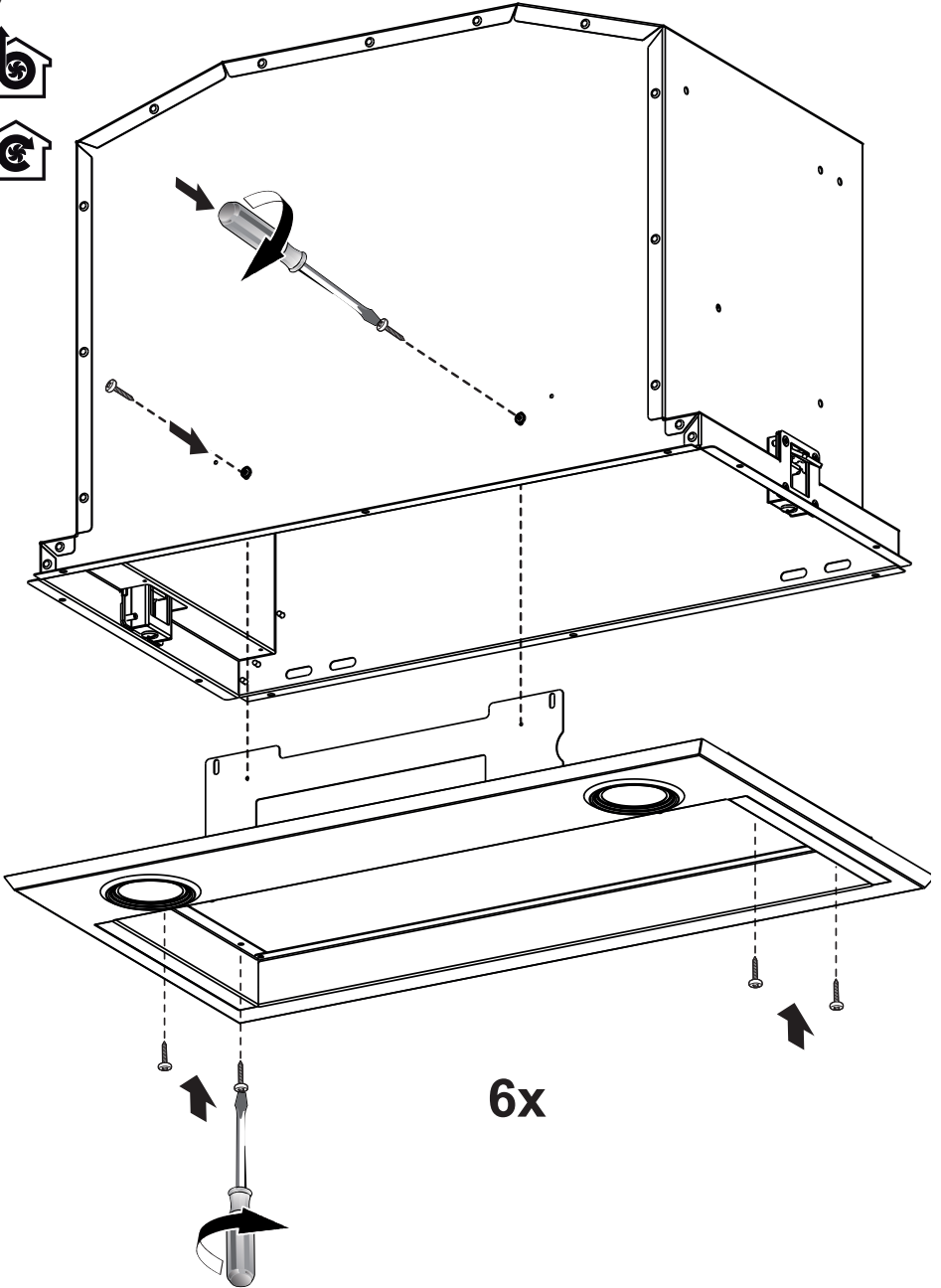

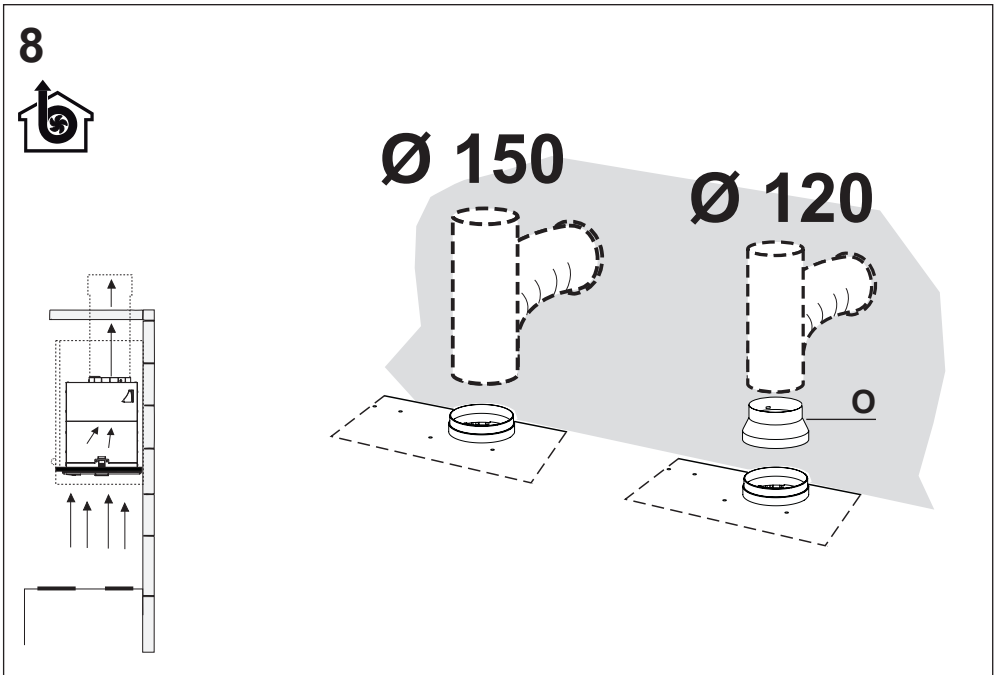
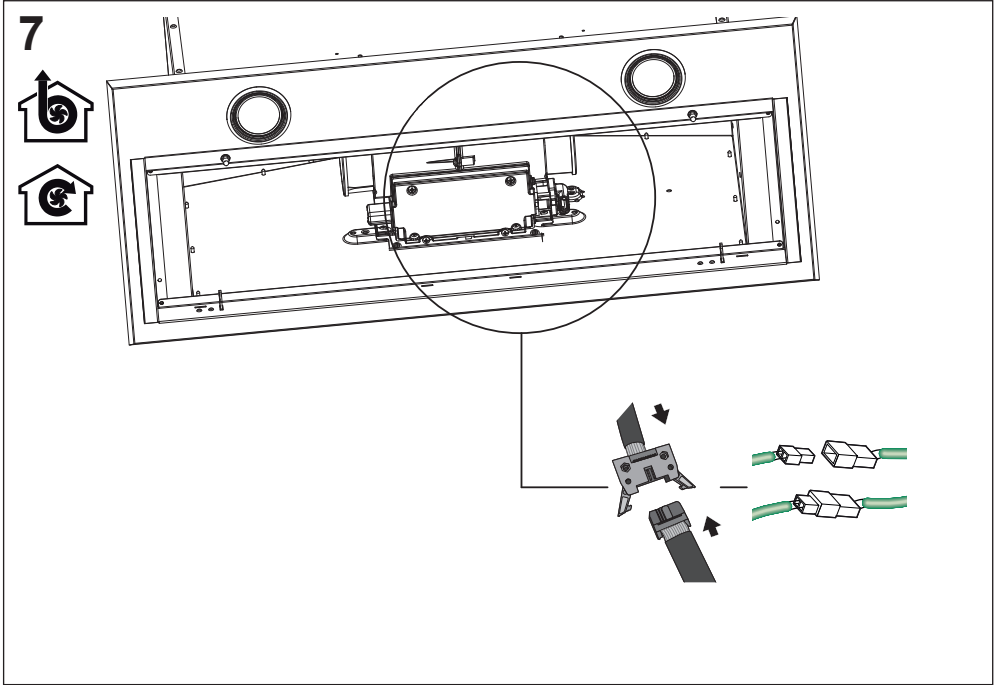

9

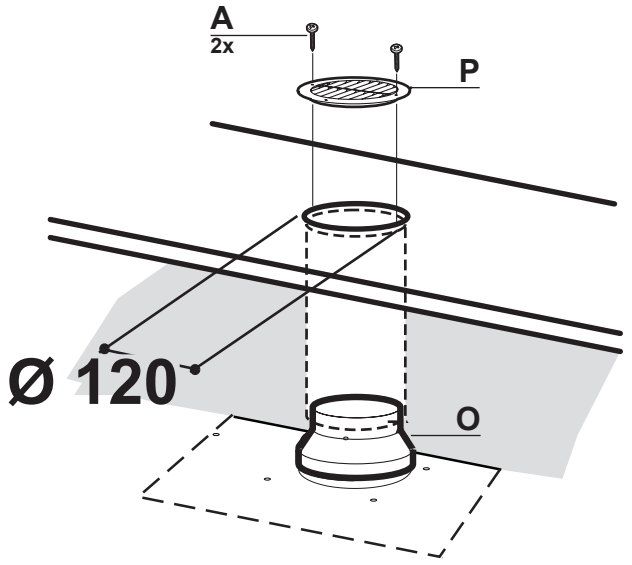
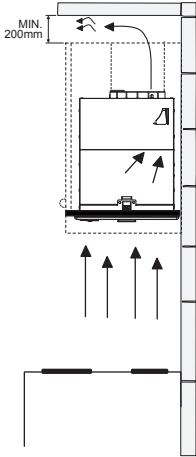

10

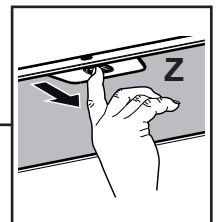
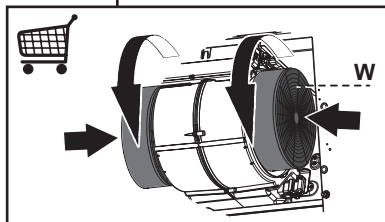
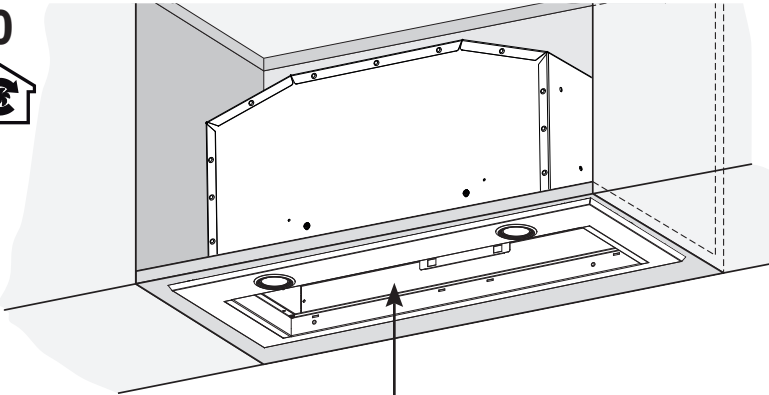

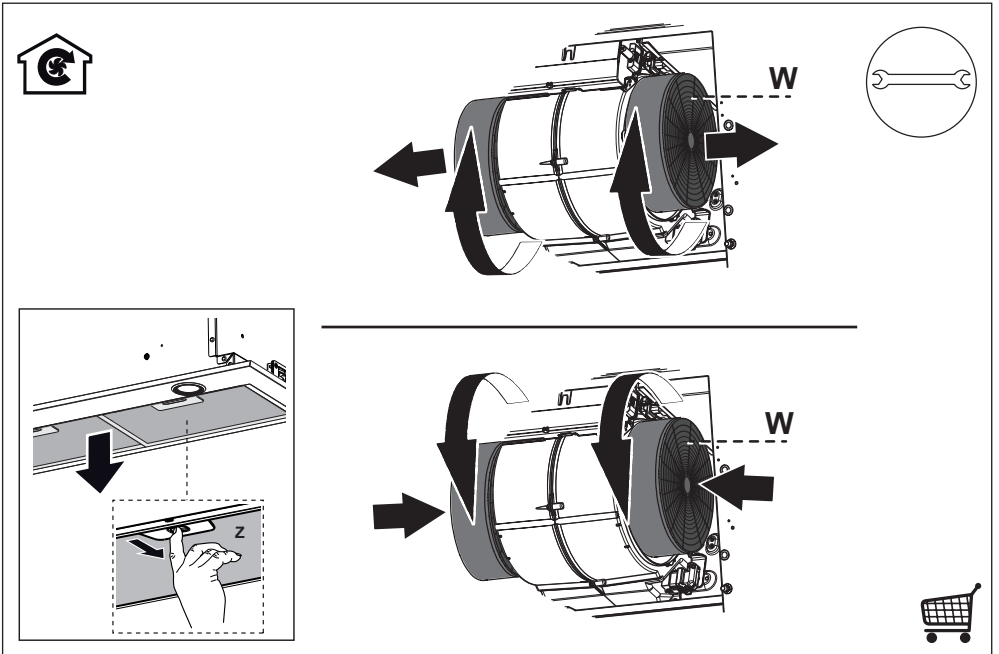
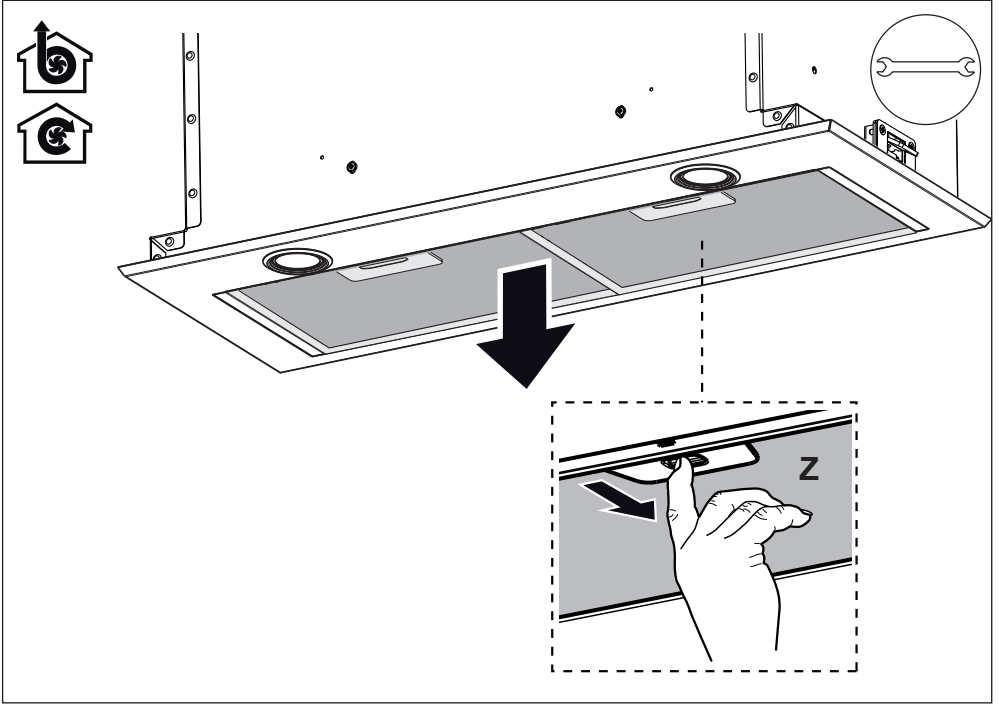



Product Guarantee

For nationwide service

UK – Tel: 0344 463 9705

EIRE – Tel: 00353 (0) 1842 4833

Guarantee

What the guarantee covers

Our service division will repair or replace free of charge any defect or component that is due to faulty material or workmanship, provided that such a defect occurs within 2 years of date of purchase and that:

1. Our service division is notified promptly of any defects. Under the terms of the guarantee, the appliance must be made available for service during normal working hours, Monday to Friday.
2. The appliance is installed in accordance with these instructions and for normal domestic use.
3. The guarantee does not apply if the appliance is repaired or modified by any other person than a member of our service division. The guarantee does not cover misuse, improper installation or any installation in commercial premises. This product is for domestic use only.
4. Any service work will generally entail removal of the telescopic flue assembly to access key components including the motor. If the flue assembly has been boxed in by means of a bridging shelf or any type of furniture this must be removed prior to our engineer's visit.

Before calling for service, please check the following:

1. Is there a power failure? Turn on the appliance to check the mains supply
2. Check that the fuse has not blown
3. Please note that bulbs are not covered under the guarantee.

In the event of service being required, our service division will request the following information:

1. Your name, address and post code
2. Your telephone numbers for home and work
3. The model number and colour of the appliance
4. Precise details of the fault
5. Date of purchase.

Please note that when the service engineer visits he will require seeing your proof of purchase date so please retain your receipt.

Britannia Customer Care

Please keep this handbook in a safe place.
Please fill in the model number and serial number in the spaces provided below as they will assist us should you need to call.

0344 463 9705

When you dial this number you will hear a recorded message and be given a number of options. This indicates that your call has been accepted and is being held in a queue. Calls are answered in strict rotation as our Customer Care Representatives become available.

Enter appliance numbers here for future reference:

Model Number: _____
Serial Number: _____

These numbers can be found on your appliances.
Outside the UK and Northern Ireland, refer to your local supplier.



Stoney Lane, Prescott, Merseyside, L35 2XW